

Bore & Stroke (mm)	150 x 150
Displacement (L)	31.8
N° of Cylinders	12
Cylinders Arrangement	At Vee
Fuel System	Mechanical
Governor (Gov.)	Electronic
Aspiration (Asp.)	T/A-A

### Customer benefits

Warranty terms – 2 yrs unlimited PRP, 4 yrs/800h ESP  
 50°C Cooling package standard with low derating  
 Low fuel consumption across the range  
 Extended MTBO

ESP/ PRP/ DCP												
Diesel Engine Models	Gross Engine Output			Typical Generator Output						RPM	Asp.	Gov.
	ESP	PRP	DCP	ESP		PRP		DCP				
	kWm			kWe	kVA	kWe	kVA	kWe	kVA			
12M26G900/5	793	725	725	720	900	652	815	652	815	1500	T/A-A	ELEC
12M26G1000/5	902	820	820	800	1000	720	900	720	900	1500	T/A-A	ELEC
12M26G1100/5	973	889	889	898	1120	816	1020	816	1020	1500	T/A-A	ELEC
12M26G2D0/5	968	880	880	880	1100	800	1000	800	1000	1500	T/A-A	ELEC
12M26G660/6	748	680	-	660	825	600	750	-	-	1800	T/A-A	ELEC
12M26G704/6	792	720	720	704	880	640	800	640	800	1800	T/A-A	ELEC
12M26G800/6	902	820	820	800	1000	720	900	720	900	1800	T/A-A	ELEC
12M26G900/6	1012	920	920	900	1125	800	1000	800	1000	1800	T/A-A	ELEC
12M26G2D0/S	968	880	-	880	1100	800	1000	-	-	1800	T/A-A	ELEC
12M26G1000/6^	1115	1014	-	1000	1250	910	1138	-	-	1800	T/A-A	ELEC

\* Please note that models ending with S are switchable engines

COP										
COP Diesel Engine Models	Gross Engine Output		Typical Generator Output				RPM	Asp.	Gov.	
	COP	PRP	COP		PRP					
	kWm		kWe	kVA	kWe	kVA				
12M26G2D0/5	720	889	652	815	816	1020	1500	T/A-A	ELEC	
12M26G2D0/6	820	920	720	900	800	1000	1800	T/A-A	ELEC	



## Dimensions and dry weight (mm/kg)

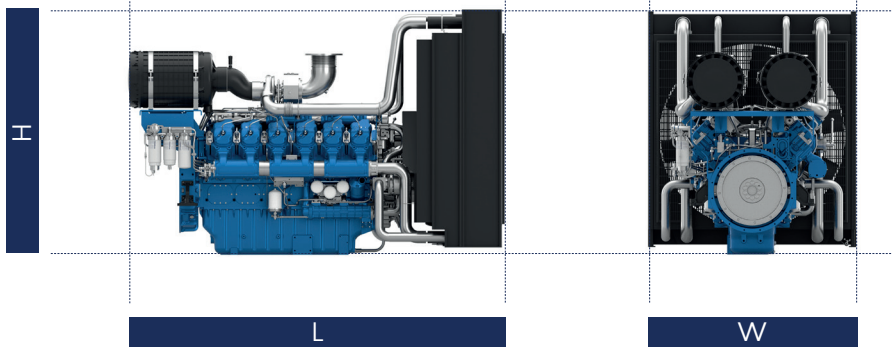

Diesel Engine	Speed RPM	Dimensions and dry weights			
		L mm	W mm	H mm	Weight kg
12M26G900/5	1500	3162	1748	2150	3585
<b>12M26G1000/5</b>	<b>1500</b>	<b>3162</b>	<b>1748</b>	<b>2150</b>	<b>3585</b>
12M26G1100/5	1500	3162	1748	2150	3585
12M26G2D0/S	1500/1800	3162	1748	2150	3356
12M26G660/6	1800	3162	1748	2150	3585
12M26G704/6	1800	3162	1748	2150	3585
12M26G800/6	1800	3162	1748	2150	3585
12M26G900/6	1800	3162	1748	2150	3585
12M26G1000/6^	1800	3525	2241.5	2243	4585
12M26G2D0/5	1500	3483	2241.5	2243	4375
12M26G2D0/6	1800	3483	2241.5	2243	4385

## Standard Equipment

Engine and block	Cast iron cylinder block with inspection door per cylinder Cast iron cylinder liners, wet type and replaceable valves guides and seats Separate cast iron cylinder heads with 4 valves Hardened steel forged crankshaft with induction hardened journals, crank pins and radius Lube oil cooled light alloy pistons with high performance piston rings
Cooling System	Radiator and hoses supplied separately Thermostatically-controlled system with belt driven coolant pump and pusher fan
Lubrication system	Full flow screw able oil filters Lube oil purifier with replaceable cartridge Water cooled lube oil cooler
Fuel system	In line fuel injection pump with flanged electronic governor Duplex fine filter and water separation filter assembly with transparent cup for better efficiency Electric fuel priming pump integrated in the filters support
Air intake and exhaust system	Top mounted turbocharger optimized for gen-set application Special rear mounted air filter with restriction indicator Exhaust manifold and turbocharger shield for heat isolating
Electrical System	24 Vdc electric starter motor and battery charging alternator LOP + HWT sensors
Flywheel and housing	SAE 0 flywheel housing and 18" flywheel

## Ratings definitions

### Emergency Standby Power (ESP)

Emergency Standby Power is the maximum power available for a varying load for the duration of a main power network failure. The average load factor over 24 hours of operation should not exceed 70% of the engine's ESP power rating. Typical operational hours of the engine is 200 hours per year, with a maximum usage of 500 hours per year. This includes an annual maximum of 25 hours per year at the ESP power rating. No overload capability is allowed. The engine is not to be used for sustained utility paralleling applications.

### DCP

Data Centre Power is defined as being the maximum power which a generating set is capable of delivering while supplying a variable or continuous electrical load and during unlimited run hours. Depending on the sites to supply and the availability of reliable utility, the generating set manufacturer is responsible to define what power level he is able to supply to fulfil that requirement including hardware or software or maintenance plan adaptation.

### Continuous Power (COP)

Continuous Power is the maximum power available for an unlimited period of use at a constant load factor. No overload capability is allowed.

### Unlimited Prime Rated Power (PRP)

Prime Power is the maximum power available for unlimited hours of usage in a variable load application. The average load factor should not exceed 70% of the engine's PRP power rating during any 24 hour period. An overload capability of 10% is available, however, this is limited to 1 hour within every 12 hour period.

- 1) All ratings are based on operating conditions under ISO 8528-1, ISO 3046, DIN6271. Performance tolerance of  $\pm 5\%$ .
- 2) Test conditions: 100 kPa, 25°C air inlet temperature, relative humidity of 30%, with fuel density 0.84 kg/L.  
Derating may be required for conditions outside these; please contact the factory for details.
- 3) Power output curves are based on the engine operating with fuel system, water pump and lubricating oil pump; not included are battery charging alternator, fan and optional equipment.